

CODEAVOUR 6.0

INTERNATIONAL

Track 2 - Climate Action Challenge

Rules and Regulations



Leveraging AI and Robotics
to Shape a Greener Tomorrow

Table of Contents - Track 2 - Climate Action Challenge

1. Introduction..... 2

 1.1. Registration Criteria..... 3

 1.1.1. Team Registration..... 4

 1.1.2. Learning Resources..... 4

 1.1.3. General Rules and Regulations..... 4

2. Game Arena and Specifications..... 5

 2.1. Arena for Climate Action Challenge..... 6

 2.2. Game Objects, Positioning, and Randomization..... 7

 2.2.1. Game Objects..... 7

 Quarky Cubes and Small Cubes with Hook..... 7

 Unique Mechanisms and Objects..... 8

 2.3. Arena Set-up..... 9

 2.3.1. Camera Setup..... 10

 2.3.2. Camera Specification..... 10

3. Rules for Age-wise Categories..... 11

4. Climate Action Challenges..... 12

 4.1.1. Challenge 1: Protecting the Forest..... 13

 4.1.2. Challenge 2: Making Roof Gardens..... 14

 4.1.3. Challenge 3: Repurposing Tyres..... 15

 4.1.4. Challenge 4: Reusing Battery..... 16

 4.1.5. Challenge 5: Recycling Battery (using AI and ML)..... 17

 4.1.6. Challenge 6: Enhancing Solar Cell Efficiency..... 19

 4.1.7. Challenge 7: Constructing Coastal Barriers..... 20

 4.1.8. Challenge 8: Safeguarding Aquatic Life..... 21

5. Robot Material and Regulations..... 24

6. Game Cards..... 26

7. Before the Competition Round..... 28

7. During the Competition Round..... 29

 7.1. Do’s..... 29

 7.2. Don’ts..... 30

8. Fouls..... 31

 3. When a challenge is attempted in manual mode..... 31

 4. When a challenge is attempted in autonomous mode..... 33

9. Evaluation and Scoring..... 36

10. Change Notes..... 39

11. Glossary..... 40

1. Introduction

Engage in a thrilling competition where your Artificial Intelligence (AI) powered robots navigate the competition arena, taking up the **Climate Action Challenge**. Let the tech wizard in you take over as you save the city of Harborton and take its future on the path of sustainability. Showcase your expertise in AI, Robotics, Machine Learning, and Intelligent Systems and gain valuable insights along the way!

In the Codeavour 6.0 International, Track 2, the **Climate Action Challenge** is a physical robotics competition. The participants will design and build their own **Robot with Quarky** to complete various object placing and other interactive challenges.

In Track 2, your robot will help develop, repair, and manage the ecosystem of Harborton in the different Climate Action Challenges.

The robot control can be **Autonomous** (programmed to follow a predetermined path using the line-following techniques) or **Manual** (directly controlled using your device) and must be Do-It-Yourself (DIY).

Codeavour International helps students develop their 21st Century skills and creativity in the following areas:

- Coding
- Robotics Concept
- Engineering Skills
- Artificial Intelligence
- Strategy and Planning
- Real-world problem-solving

1.1. Registration Criteria

You must adhere to these guidelines:

- Each team can have a maximum of three members and must have one adult mentor/coach/guardian.
- The age group for track 2 is as follows:
 - **Elementary:** 7-10 Years
 - **Junior:** 11-14 Years
 - **Senior:** 15-18 Years

All the participants must meet the age group and team size criteria.

1.1.1. Team Registration

To register for this competition, participants must visit the Codeavour 6.0 International website and complete the registration process:

Registration Link: <https://codeavour.org/register/>

Complete your team registration to participate in the world's biggest Coding, AI and Robotics Festival for students!

1.1.2. Learning Resources

Participants can access learning resources on the Codeavour 6.0 official website, which offers e-learning resources for Coding, AI, Robotics, Machine Learning and more.

LMS: <https://t.ly/j9rP0>



1.1.3. General Rules and Regulations

In order to ensure a seamless and enjoyable experience for all, participants are recommended to strictly adhere to the established rules and regulations.

The robot should be programmed using **PictoBlox** only. Participants can use any coding environment inside the PictoBlox.

- The participants must only make a robot using **Quarky**.
- Mentors, coaches, teachers, parents, or guardians are not allowed in the competition area, and must not be **directly involved** in controlling or manipulating the robot during the competition. Their role is limited to providing mentorship and guidance only. Any direct involvement in robot control will result in the team's disqualification.
- Each team must have their own distinct robot adhering to the provided material and regulatory guidelines. Sharing robots across multiple teams is strictly forbidden and could lead to disqualification.
- Participants must maintain discipline and follow the competition rules and regulations of the competition management authority. Any individual found violating the rules or causing disruptions may result in the disqualification of their team.
- Teams have the flexibility to devise their own strategy and rearrange the order of challenges.
- Check out the video:
 - ▶ [Codeavour 6.0 Track 2: Climate Action Challenge | Rules & Guidelines](#)
- The Codeavour team may introduce **additional challenge(s)** for the international round for an engaging experience for the participating teams.

Stay tuned for updates!

2. Game Arena and Specifications



Game Field Size: 45 in x 93 in

- Width of the white path: 15 cm
- Width of the black line: 1.5 cm

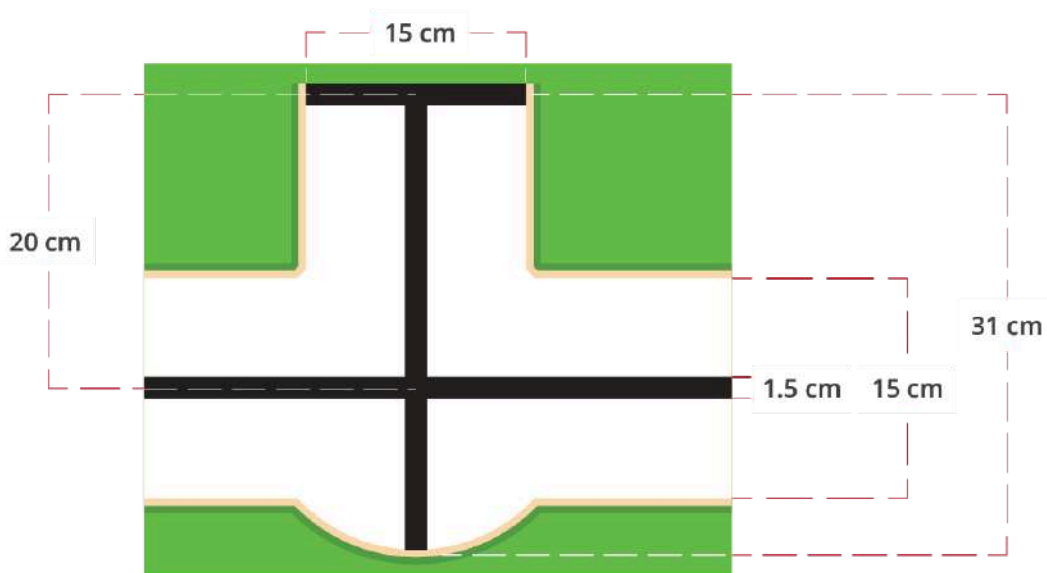

Pathway Dimensions

The arena printed on high-quality **Grey Back Vinyl** is clearly marked with red and green outlines to indicate the designated pickup and drop points for the cubes respectively.

All objects are initially positioned at Pick-up points (red), and the robot must successfully transport them to the corresponding Drop points (green) as part of the challenge.

Detailed information is provided in Section 4 (Climate Action Challenges).

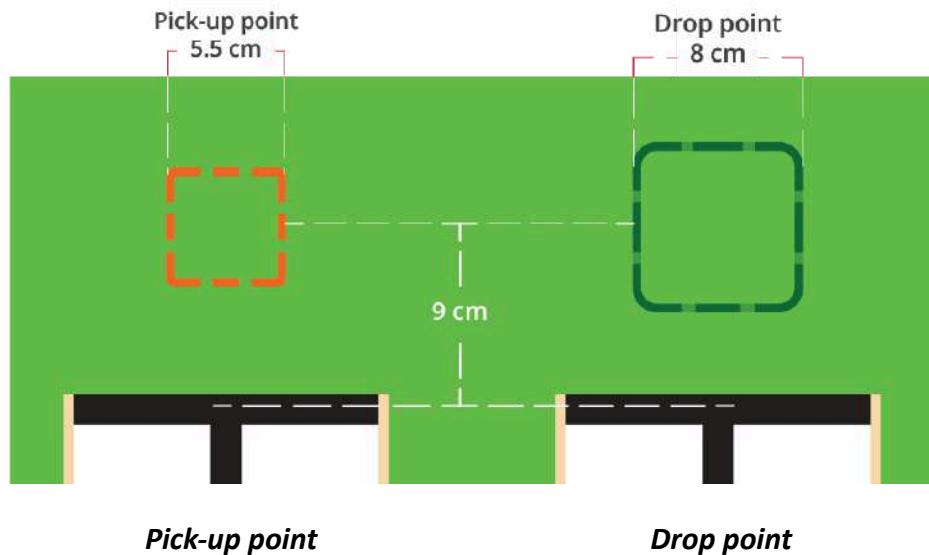

2.1. Arena for Climate Action Challenge



2.2. Game Objects, Positioning, and Randomization

A variety of objects are strategically placed within the arena for the challenges, with each element tailored to the specific task. These objects may include small cubes equipped with hooks, as well as distinctive cubes with unique appearances. Additionally, the arena will feature mechanical elements that robots must interact with, as outlined below:

2.2.1. Game Objects

Quarky Cubes and Small Cubes with Hook

Participants can use various methods such as Pick, Grab, Push, Pull, and more to move the cubes and complete the challenges.



1. Charging Dock



2. Roof Garden



3. Used Tyres



4. Used EV Battery



5. Expired Wet Battery



6. Expired Dry Battery



7. Waste Bin 1



8. Waste Bin 2



9. Plastic Waste

Unique Mechanisms and Objects

The robot must interact with unique objects or adjust the orientation of its mechanisms. At the start, each unique object and mechanism, labelled from A to E, will be positioned in specific locations within the arena. During the game, the robot will engage with them to complete the challenges.

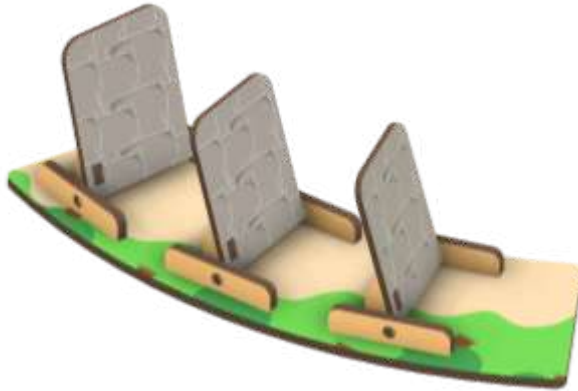

(A) Coastal Barrier

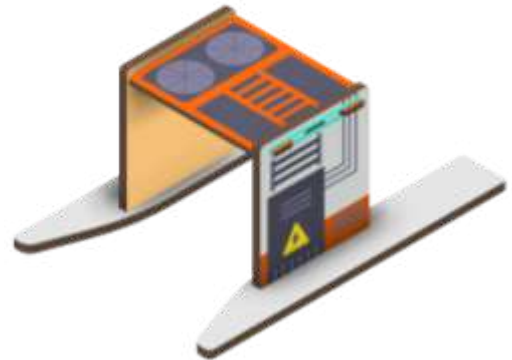

(B) Sub Station



(C) Fire Safety Robot
Launch Pad



(D) Building

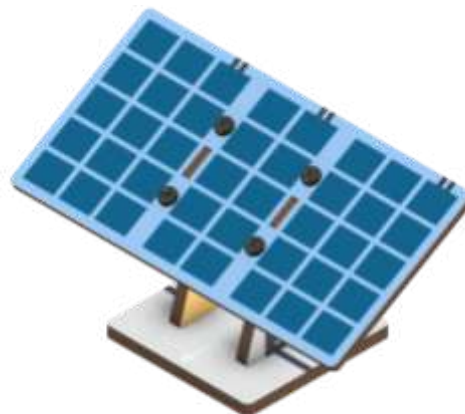

(E) Solar Panel

2.3. Arena Set-up

- **Initial Configuration:** All game objects will be arranged in the arena according to the setup diagrams provided below.

Note: Before the match, the judge will decide and randomly place any one out of two types of cubes for Challenge 5.

- **Pickup Points:** The Quarky Cubes and Small Cubes with Hook will be positioned at the Pick-up point from where the robot has to move them as per the challenge.



Initial positions of game objects (Elementary)



Initial positions of game objects (Junior/Senior)

- **Area:** The pit area will be marked with yellow and black floor marking tape.
- **Team Space:** Team members will have a designated area of 3 feet around the arena inside the pit for their movement and observations.

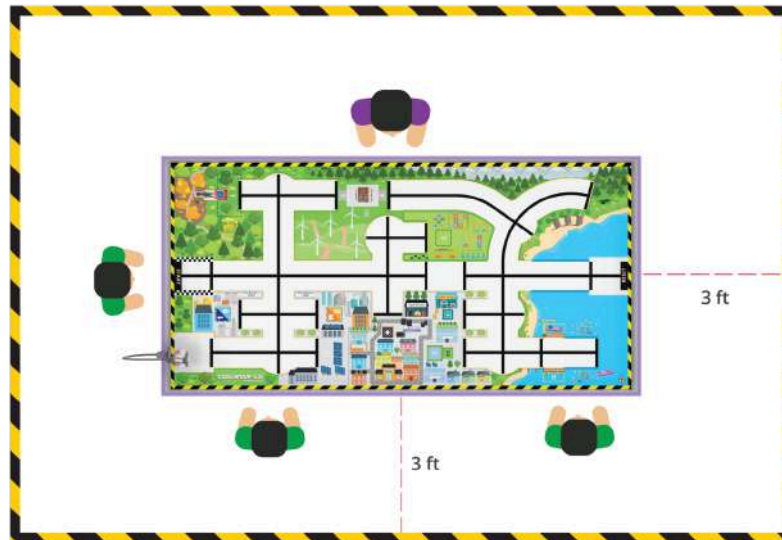

Arena Pit Area

2.3.1. Camera Setup

A web camera will be placed on the recognition point in the arena at a height of 23 cm from the arena for Challenge 5.

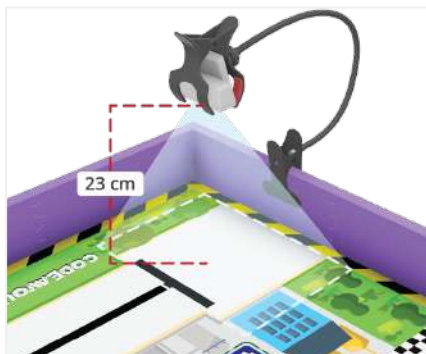

Camera Position

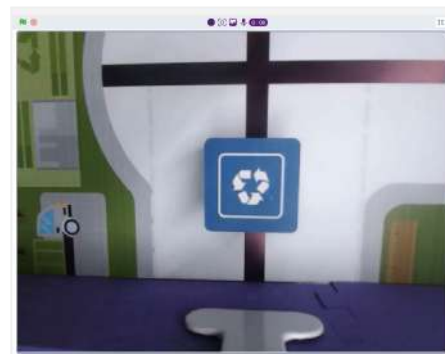

Camera Field of View

Note: The participant(s) must consult with the judge regarding the camera configuration. They are not permitted to handle or adjust the camera mount/camera before or during the match.

2.3.2. Camera Specification

Connection Type: Wired, USB 2.0
Camera FOV: DFOV 95°

Capture Resolution:
FHD (1920 x 1080)

(Recommended camera: Lenovo 300 FHD Webcam)

3. Rules for Age-wise Categories

To successfully complete the challenges, participants adhere to the rules specified for their age group:

1. Elementary (7-10 years):

- a. Participants in the elementary age group can complete all challenges entirely using either a manual robot or an autonomous robot.
- b. The total time for the Elementary age group is **4 minutes** to complete the challenges.
- c. For Challenge 5, quarky cubes featuring pre-trained images of numbers from the “recognition cards extension” will be utilized for the elementary age group.
- d. The team will be provided with 2 Restore Cards, allowing the team to reposition the arena object to complete the challenge.

2. Junior (11-14 years)/ Senior (15-18 years):

- a. The Junior and Senior participants can use manual or autonomous modes but must perform **at least one challenge autonomously**.
- b. The total time for the Junior and Senior age groups is **3 minutes** to complete the challenges.
- c. For AI Challenge 5, the team will be required to train images of the cubes in the Machine Learning Environment of PictoBlox in order to complete the Challenge successfully.
- d. The team will be provided with 1 Restore Card, allowing the team to reposition the arena object to complete the challenge.

Note: *Completing a challenge with autonomous robots is rewarded with double points compared to manual robots for that challenge. This strategic choice boosts a team's score significantly, offering a competitive advantage.*

4. Climate Action Challenges

The Climate Action Challenge begins in the city of Harborton, where the rise in temperature is breaking all records. It is a stark reminder of humanity's unchecked consumption. Its forests are withering and the water levels are rising as the ice caps are melting at an alarming rate. The future of Harborton depends upon young innovators armed with technology and a spirit of adventure as they embark on a quest to restore health and balance to the city.

There are 8 Climate Action Challenges in total. Each challenge will test your technical skills and impart core learnings of real-world problems associated with climate change. Teams have the freedom to come up with their own strategy and determine the sequence of challenges with their robot.

Here's the overview of the challenges that lie ahead.

4.1.1. Challenge 1: Protecting the Forest

The Forest near Harborton is on fire. If trees are lost to disasters, it will be impossible to stop global warming.

Forests absorb carbon dioxide (CO₂) from the atmosphere, acting as carbon sinks. To make matters worse, burning forests also emit large amounts of CO₂, further contributing to an increase in global warming and damaging the ecosystem.

*Your task is to use your robot to unplug the **charging dock** from the **fire-fighting robot** at the nearest **fire safety robot launch pad** to stop the wildfire in the forest.*



Challenge 1: Initial Position



Challenge 1: Final Position

4.1.2. Challenge 2: Making Roof Gardens

Green roofs absorb sunlight and release water vapour, cooling the surrounding area and mitigating the urban heat island effect, which is a big contributor to global warming. Harborton will benefit by adopting this practice in their industry-ridden areas. Harborton needs your robot to install plants on buildings.

Your task is to construct a **Roof Garden** on top of the building with your robot.



Challenge 2: Initial Position



Challenge 2: Final Position

4.1.3. Challenge 3: Repurposing Tyres

Repurposing tyres provides a potent way to deal with tyre waste more efficiently. This mitigates climate change caused by malpractices in waste disposal such as burning tyres. This releases huge amounts of greenhouse gasses, contributing to global warming. Pollutants from tyre fires also play a role in Ozone layer depletion.

*Your task is to use your robot to move **used tyres** from the Tyre Service to the Eco-Park to repurpose them to create play equipment for the kids.*



Challenge 3: Initial Position

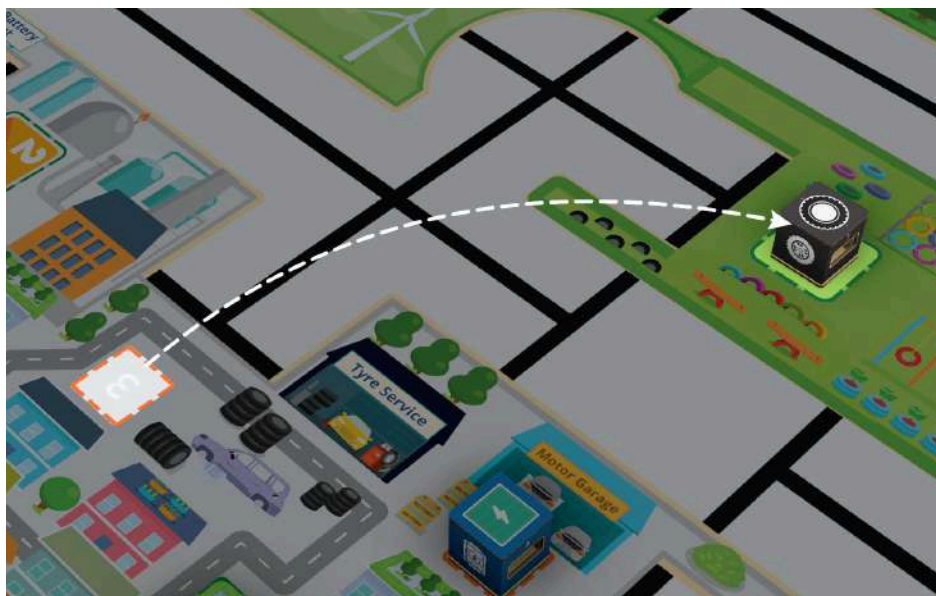

Challenge 3: Final Position

4.1.4. Challenge 4: Reusing Battery

Reusing batteries helps to reduce the amount of electronic waste created globally and using renewable energy reduces dependence on fossil fuels for power generation. Batteries no longer suitable for EVs or high-demand applications can still be used for less demanding uses. Renewable energy plants can utilize these repurposed batteries to store the generated power.

*Your task is to use your robot to transport the **used EV battery** from the Motor Garage to the Wind farm to replace the expired battery at the substation.*



Challenge 4: Initial Position

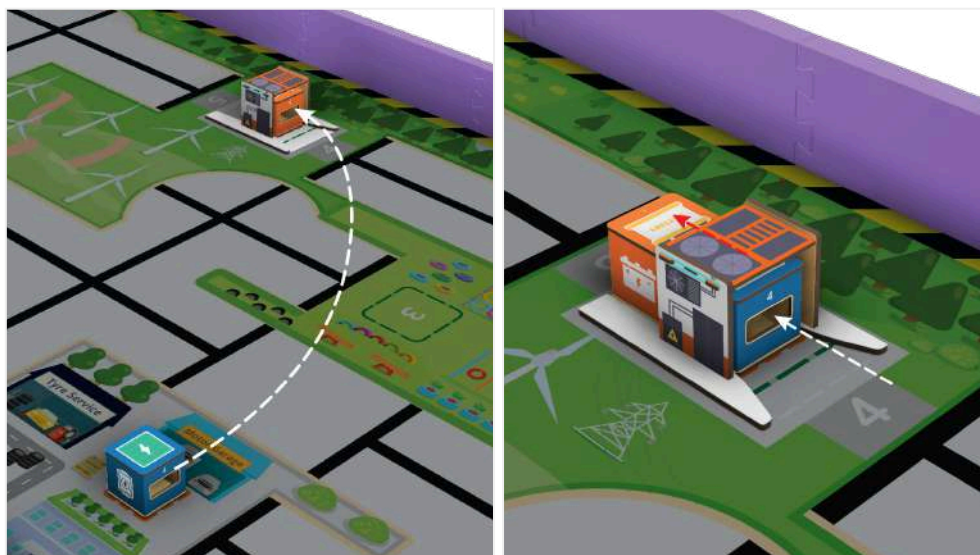

Challenge 4: Final Position

4.1.5. Challenge 5: Recycling Battery (using AI and ML)

The increasing number of electronic devices has led to a surge in battery waste. Recovery of its raw materials and recycling them reduces the need for mining more. This also eliminates carbon emissions from the processing of mined ores into usable raw materials. Further, it prevents improper disposal of batteries, a leading cause of severe soil and water contamination.

To address this issue, Harborton plans to collect, sort and deliver the used batteries to their respective recycling plant.

*Your task is to use your robot to collect the **expired battery cube*** from the Wind Farm Substation, identify its type at the Camera Point, and deliver it to the respective Wet or Dry Battery Recycling Plant.*

Read **Conditions in the next section for details.*



Challenge 5: Initial Position (before completing Challenge 4)



Challenge 5: Initial Position (after completing Challenge 4)



Challenge 5: Final Position

Conditions:

- Before starting, the judge will randomly place one of two cubes on the Pickup Point 5 **Wind Farm Substation**.
- After completing challenge 4, the team's robot can push the respective cube out of the Wind Power Substation or pull it from the Wind Farm Substation before completing challenge 4.
- In this challenge, **Junior/Senior** participants' robot should identify the expired battery type (Wet or Dry) and deliver it to the respective drop point using their own image classifier model trained in the Machine Learning (ML) Environment of PictoBlox.



Expired Wet Battery



Expired Dry Battery

or



Note: Teams can take images of the Wet and Dry Battery cubes for the image classifier model training by either preparing their own cubes from the print-ready files in [arena resources](#) or getting their own Codeavour Arena Objects kit.

- **Elementary** participants' robot should utilise artificial intelligence (AI) based card recognition extension in PictoBlox to identify the expired battery type (Number 1 or 2). The recognised card's colour or number should be displayed on the Quarky display for 2 seconds. Further, the robot must deliver it to the respective drop point.



Waste Bin 1



Waste Bin 2

or

The participants can access the [learning resources](#) to learn more.



Note: For the card recognition Challenge, participants must display the output on Quarky as shown in the images given below or they may show the cube's name on PictoBlox Stage.

4.1.6. Challenge 6: Enhancing Solar Cell Efficiency

Solar panels are renewable sources of energy and they generate electricity without burning fossil fuels. Switching to Solar Power significantly reduces greenhouse gas emissions. The Battery Recycling Plant at Harborton runs on solar energy. Help them harvest more energy by automating the sun-tracking of the solar panels.

*Your task is to adjust the angle of the **solar panel** to the west to follow the Sun and, enhance solar cell efficiency and boost power production.*

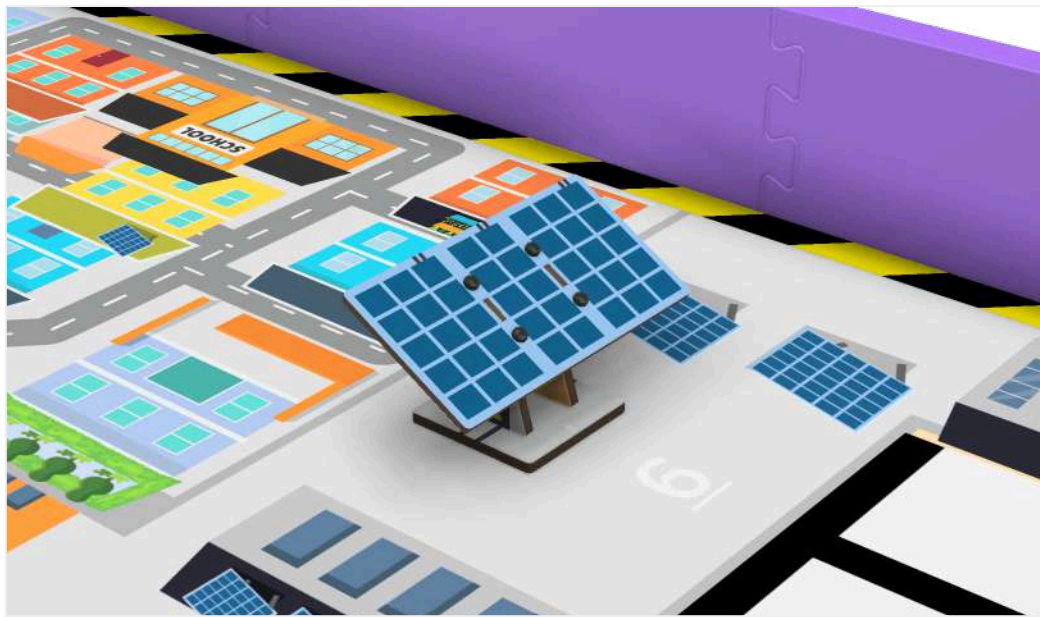

Challenge 6: Initial Position

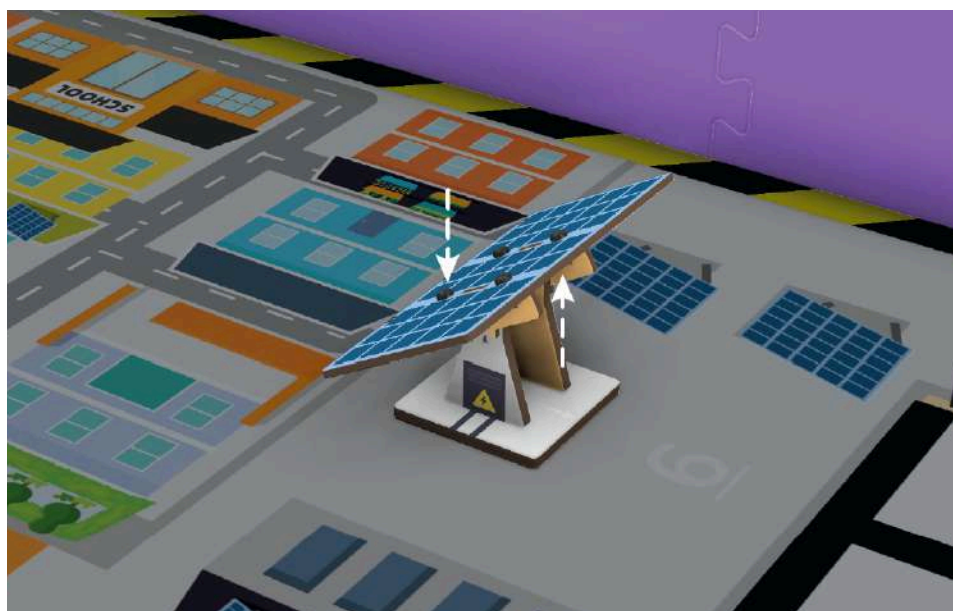

Challenge 6: Final Position

4.1.7. Challenge 7: Constructing Coastal Barriers

Coastal ecosystems among many vital roles, play a crucial role in combating climate change as carbon sinks by absorbing atmospheric CO₂. Rising sea levels are a major threat to them. Harborton plans to lay eco-friendly sediment bags to help safeguard these invaluable coastal defences against global warming.

*Your task is to use your robot to lay fortifying **coastal barriers** of eco-friendly sediment bags.*

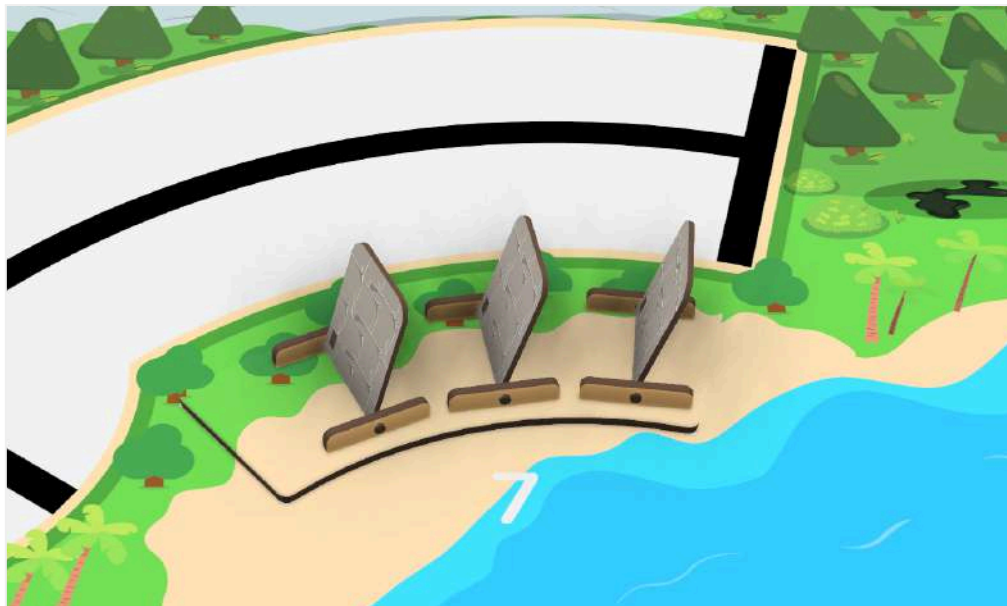

Challenge 7: Initial Position

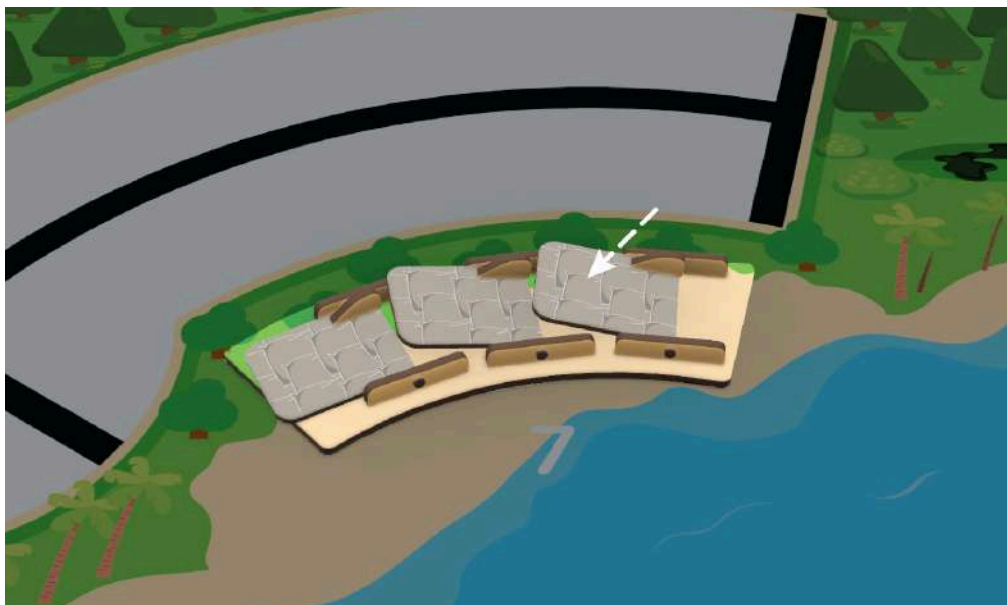

Challenge 7: Final Position.

4.1.8. Challenge 8: Safeguarding Aquatic Life

Aquatic plants like phytoplanktons and seagrasses absorb carbon dioxide from the atmosphere and play a crucial role in supporting the aquatic ecosystem. Sadly, water pollution and floating plastic in water block sunlight. This prevents the phytoplanktons from producing energy through photosynthesis and absorbing carbon dioxide.

To restore the balance, Harborton calls upon your skills to perform deep clean-ups in the sea.

*Your task is to deploy your robot to clean up the sea by collecting **plastic waste** and bringing it to the Green Zone of the pier. If your robot can get it to the pier's Yellow Zone, you will be rewarded half a point.*

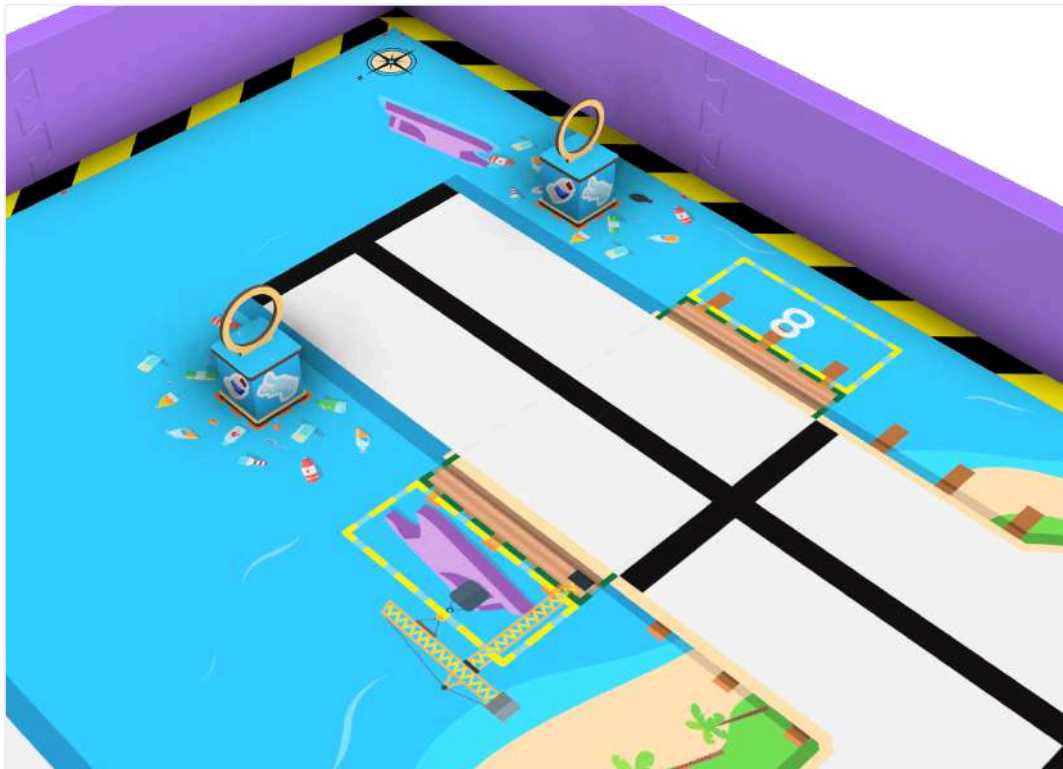

Challenge 8: Initial Position

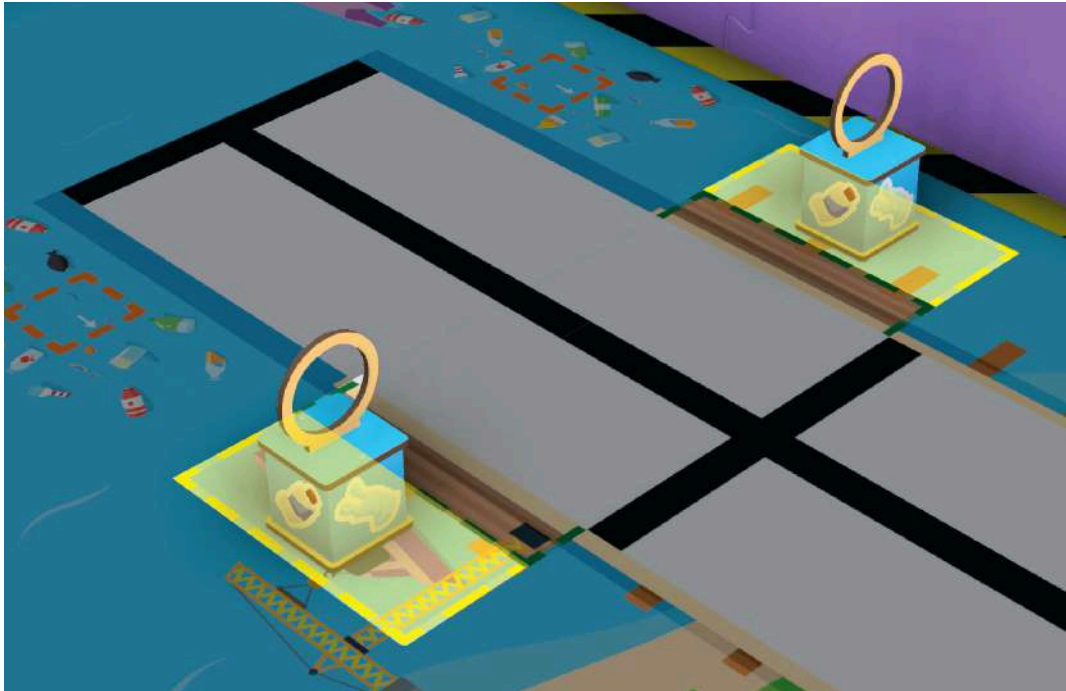

Challenge 8: Final Position

Condition 1: Both objects are in the Extended Drop Points

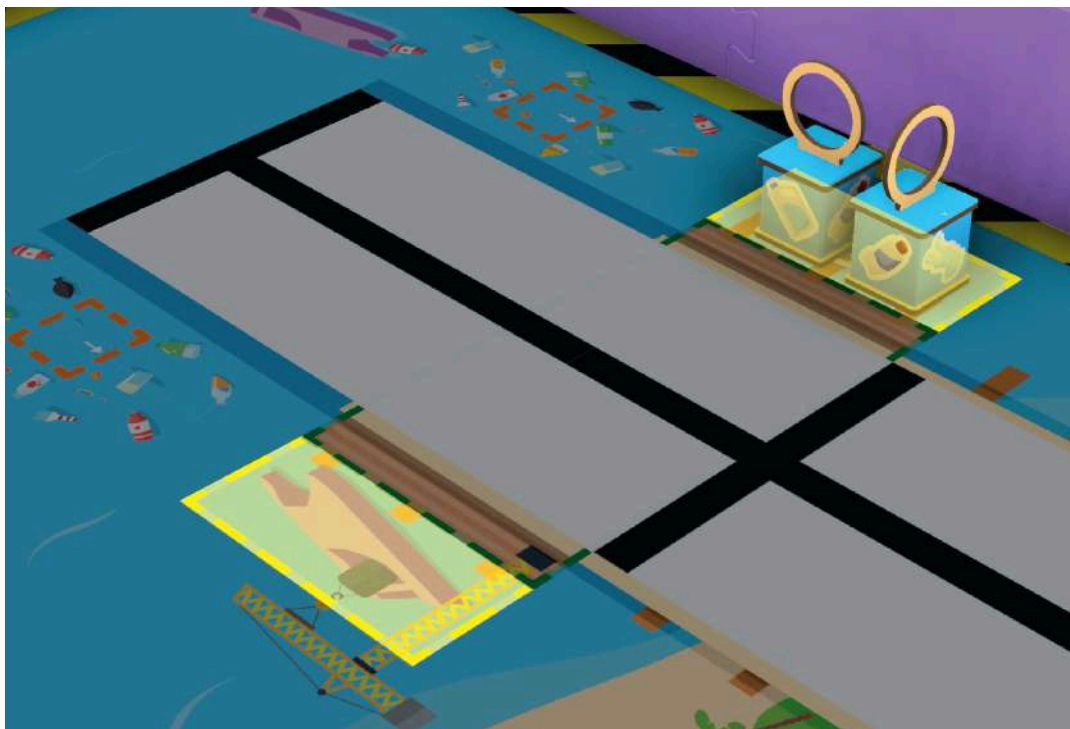

Challenge 8: Final Position

Condition 2: Both objects are in an Extended Drop Points

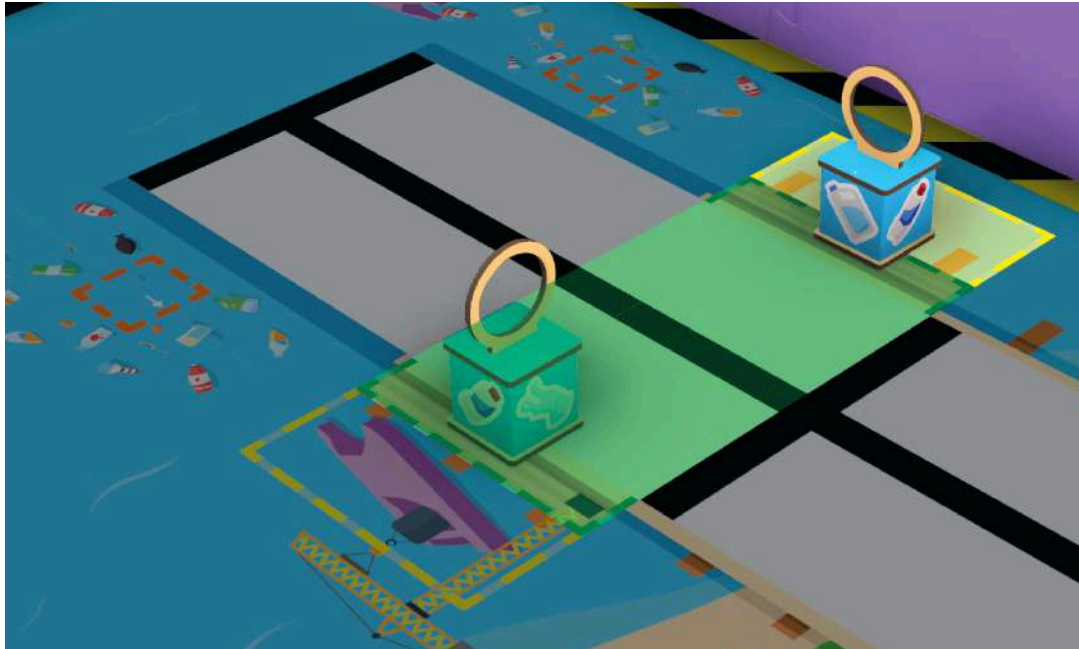

Challenge 8: Final Position
Condition 3: One object fully in the Drop Point.

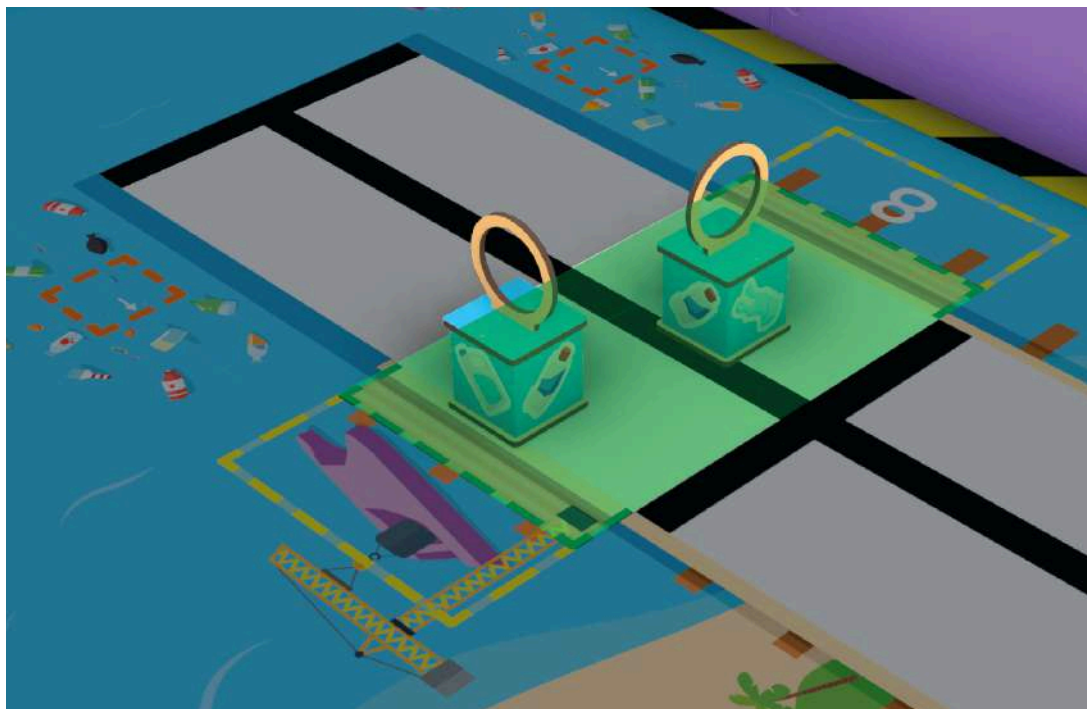

Challenge 8: Final Position
Condition 4: Both objects are fully in the Drop Point.

5. Robot Material and Regulations

A comprehensive list of all permissible hardware components brought by the team to the competition, including the robot, accessories, and any additional attachments, is provided below. The entire robot design must strictly adhere to the specified guidelines:

1. **Hardware/Microcontroller:** Quarky Board (Max qty: 1; No other microcontroller is permitted).
2. **Programming Software:** PictoBlox (Participants can use different environments available in PictoBlox).
3. **Power Supply:** A robot must be battery-operated at the time of competition, and the voltage must not exceed 5 volts between any two terminals of the Robot.
4. **Add on Board:** Quarky Expansion Board (Max qty: 1).
5. **Robot size:** The robot must be at most 20x20x20cm (LxBxH) in size. However, the robot can expand itself while in the game.
6. **Maximum Weight:** Maximum 2kg.
7. **Communication:** The robot must be wirelessly connected to PictoBlox via Bluetooth.

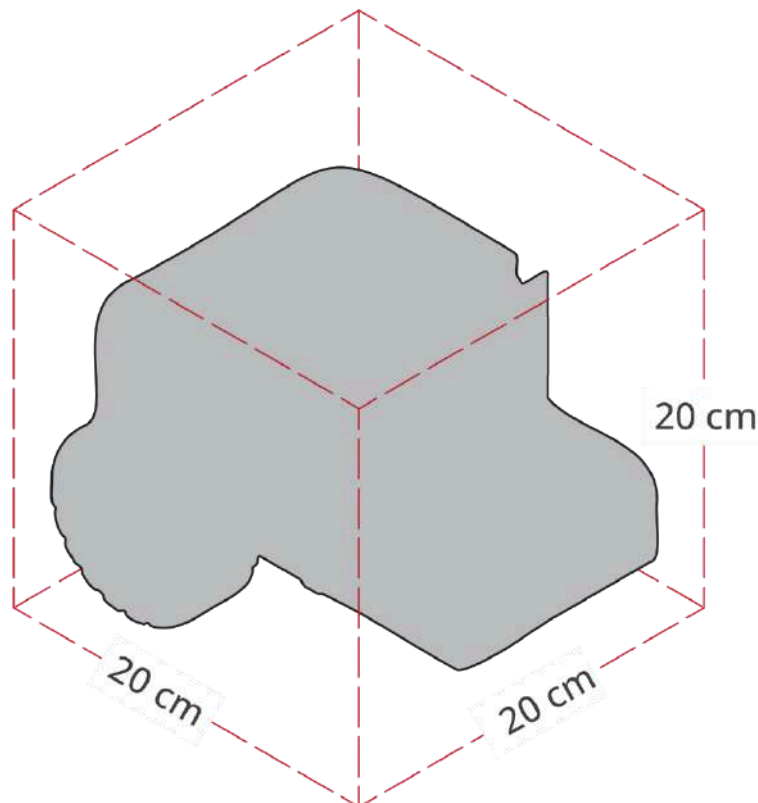

- 8. Add-on Parts:** Participants are free to choose the additional sensors and construction components as per their robot design (3D printed parts, Laser-cut parts, Lego components, Ice Cream sticks, and more).



Lego pieces

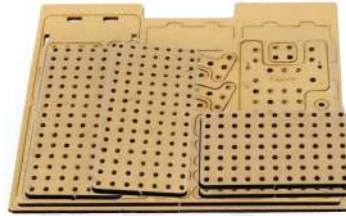

MDF parts

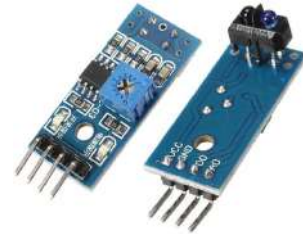

4 Pin IR sensor

Note: You can use any sensors compatible with Quarky.

The team must bring all the necessary components and tools. This includes extra batteries, power extension cords, a soldering kit, glue, fasteners, etc.

Material will not be provided at the venue by the organisers.

The Robot design must not damage the game field or any of the articles in the game field in any way.

- 9. No exposed sharp edges:** The entire design of a robot must not have sharp edges that may harm the game field or the people around it.
- 10. No hazardous materials:** The Robot parts shall not be made with hazardous materials.

6. Game Cards

1. **Elementary Teams** will receive
 - a. 1x Teleport, 2x Switch, 2x Restore Cards before the competition round.
 - b. 2x Foul Shield Cards upon unlocking them by completing specific challenges*.
2. **Junior/Senior Teams** will receive
 - a. 1x Teleport, 2x Switch and 1x Restore Card before the competition round.
 - b. 2x Foul Shield Cards upon unlocking them by completing specific challenges*.

*Teams will earn a Foul Shield Card each on the completion of Challenge 5 and another on the successful completion of Challenge 8.

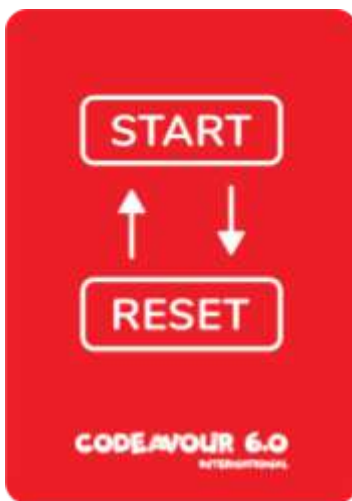

Teleport Card (1x)

6.1 Teleport Card: This card enables teams to deploy a teleportation strategy whenever the robot is either at the Start or the Reset point. Teams can pick up and move their robot from the start to the reset point or vice versa.

Teams can use this strategy to change their robot's position swiftly.

Note:

1. Teams can only use the Teleport Card while their robot is in the start or reset regions.
2. The timer won't pause during the execution of the card.

6.2 Switch Card (Switch Manual/Autonomous Mode):

The Switch Card allows teams to switch their robot's operational mode between autonomous and manual control only once using this card.

This flexibility is crucial for adapting to various challenges during the competition. Autonomous mode begets more points, while manual mode allows teams to control their robot in real-time.

Note:

1. This card can't be exercised when the robot has already interacted with a Game Object of a challenge.
2. The timer won't pause during the execution of the card.

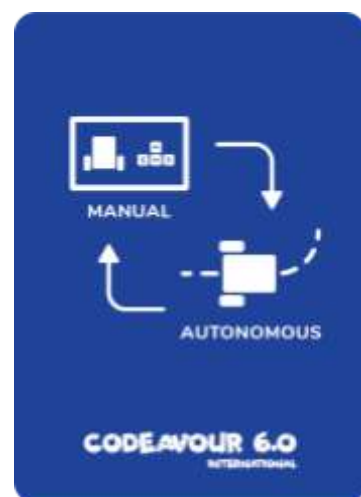

Switch Card (2x)



Foul Shield Card (2x)

6.3 Foul Shield Card (For Foul Exemptions): The team can redeem the Foul Shield Card to avoid negative scoring for a foul. This redemption acts as a foul exception, allowing the team to nullify the penalty and maintain their current score for that challenge.

Teams must use their Foul Shield Cards judiciously, as they have only two chances to waive off negative scoring due to fouls. Making strategic decisions about when to redeem these cards can significantly impact a team's overall standing in the competition.

Note:

1. The use of the Foul Shield Card to adjust/place any game object is not permitted.
2. The timer won't pause during the execution of the card.

6.4 Restore Card (Restore Cubes at Initial Position):

The green Restore Card allows teams to request the reposition of the game object(s) of any challenge to its original location and orientation before attempting the task again.

Note:

1. Only the Judge is permitted to handle and restore the cube to its initial position.
2. The card does not shield the team from the foul of touching their robot.
3. If the Team uses this card to restore the cube for Challenge 4, they can also choose to restore the cube for Challenge 5 at the same instance.
4. The timer won't pause during the execution of the card.



Restore Card (1x or 2x)

7. Before the Competition Round

1. The robot must be fully assembled in advance before the commencement of the competition round.
2. The Teams **must validate** their robot (made with Quarky) and PictoBlox code by the Codeavour robot verification team to ensure it meets the specified requirements physically at the venue. The Robot and the code must adhere to the specifications and inspection guidelines outlined in the rules.
3. The verification team can ask to disassemble the robot while inspecting it if required.
4. Teams will get their time slot and game field table before the competition round.
5. Before the competition round, the teams will be given **5 minutes** to test and set up their robots in the allotted practice arena.
6. Teams must ensure that their robot is connected to their device and that both the robot and device have fully **charged batteries** before the competition round. Any team that is not prepared at the time of their slot may lose their chance to compete.
7. Teams will receive some game cards from the Judge/Volunteer.

7. During the Competition Round

Only **2 minutes** will be given to a team to set up and calibrate their robot on their dedicated arena table before starting the competition round.

7.1. Do's

1. Only team members are allowed near the competition (pit) area.
2. The team is responsible for picking up their robot immediately on time out.
3. The robot must start from the start point.

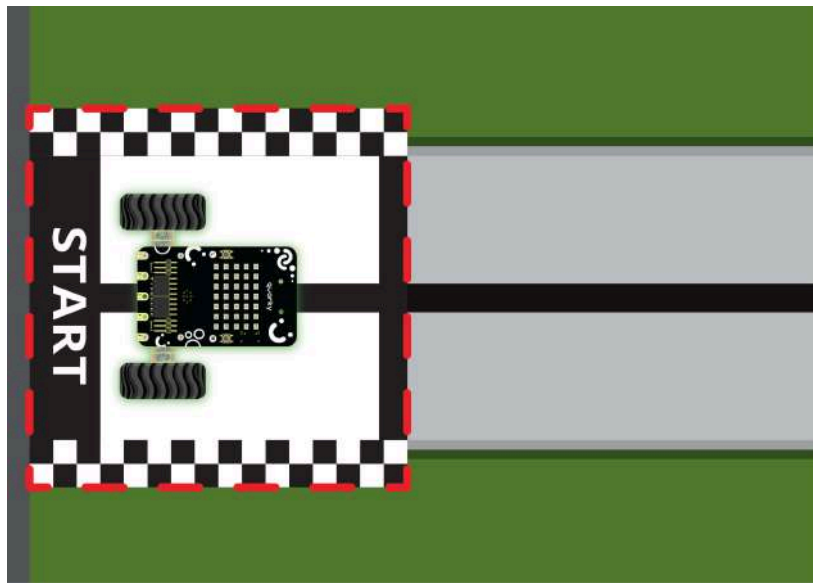

Robot Start Position

4. Robots must adhere to the specified path to approach the objects or to move across the arena.

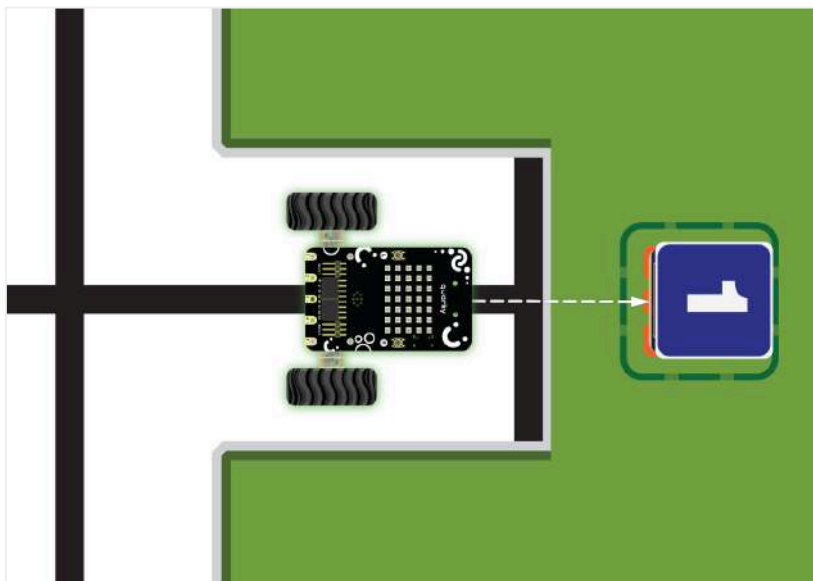

Correct Way to Approach Objects

5. Teams must raise their game card back to the Judge/Volunteer when exercising them.
6. During a challenge attempted as an autonomous challenge:
 - a. The team can build the code in parts for the robot to perform challenge(s) from one junction to another or as per the Robot Repositioning Points (see section **8. Fouls**).

7.2. Don'ts

1. Mentors/coaches/teachers/parents/guardians are not allowed inside the Pit Area.
2. Do not cause any damage to the competition field, arena, or any of the given equipment. Any such activity can result in instant disqualification.

8. Fouls

1. **Five Points will be deducted for each foul** from the total score.
2. Approaching game objects /traversing directly over other buildings or other areas of the arena is prohibited. Any activity attempted in this manner will not be considered for scoring, and one foul will be called.

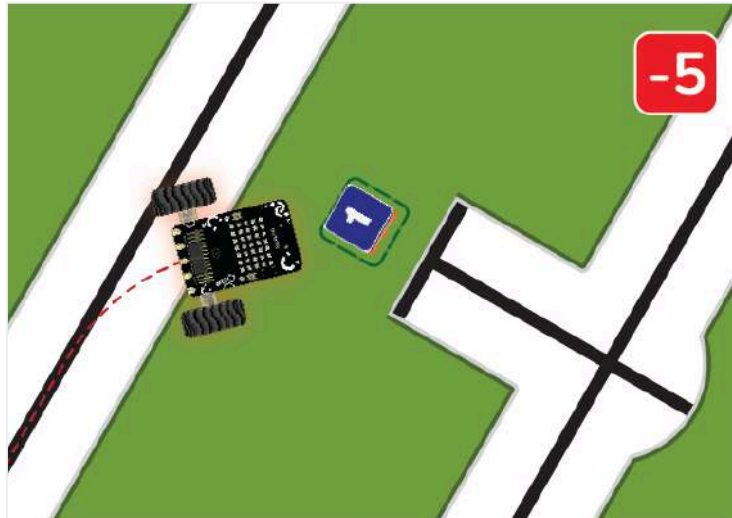

Incorrect Way to Approach Objects

3. When a challenge is attempted in **manual mode**:

- a. At any instance, if the team wants to touch the robot:

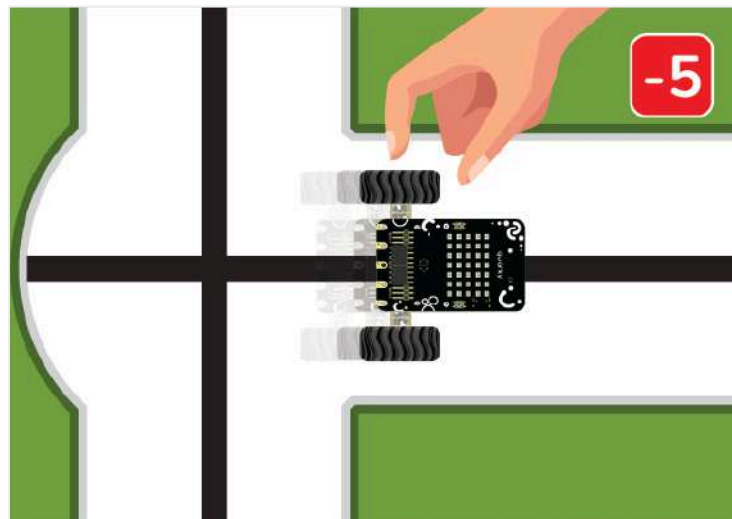

Touching the Robot

- i. The team must prompt the Judge for the same.
- ii. One foul will be called.
- iii. The team must place the robot back at the **last junction** (intersection of any two black lines) that it has crossed in the arena.

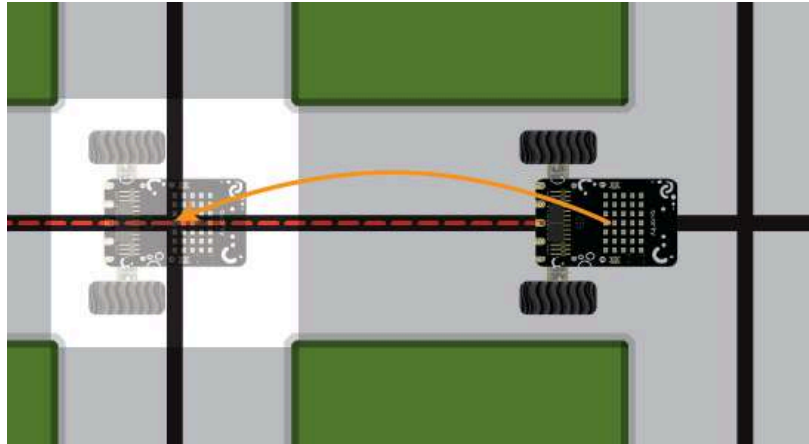

Repositioning robot at Last Crossed Junction

- iv. In case the robot is in contact with the Quarky Cube/ Small Cube(s)/ Unique Mechanisms or Objects:
 - 1. The cube(s) has to be given to the Judge/ Volunteer to be kept outside the arena.
 - 2. The Unique Mechanisms or Objects must not be touched by the team.
 - 3. This attempt at the challenge will not be scored.
 - 4. The team can further exercise the **Restore Card** (if available) at any point of time to reattempt this challenge and the Judge/ Volunteer will restore the game object(s).
 - v. The timer won't be paused.
- b. If the robot leaves the track **completely**:

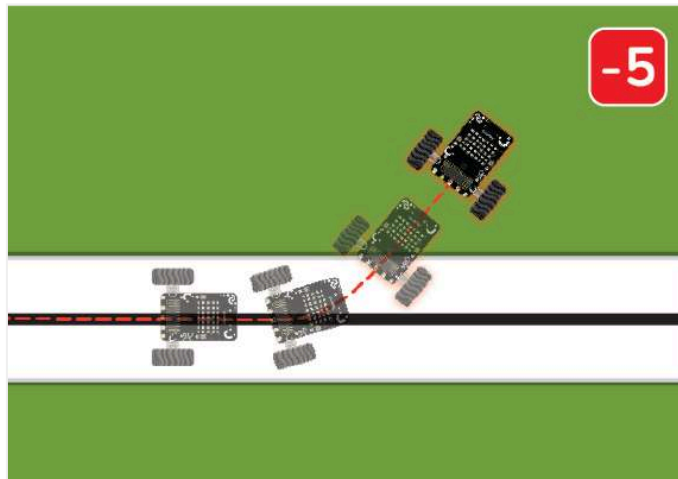

Path Deviation

- i. One foul will be called.
- ii. The robot must be moved back to the last junction that it crossed on the arena.
- iii. The timer won't be paused.

- c. If a team member touches the robot **without prompting the judge**:
 - i. One foul will be called.
 - ii. The challenge will not be scored.
 - iii. The judge will end the round.

4. When a challenge is attempted in **autonomous mode**:

- a. In case of a foul in autonomous mode, the team has to reset their robot at the below given **Robot Repositioning Points** nearest to the Drop Point of the previously attempted challenge.

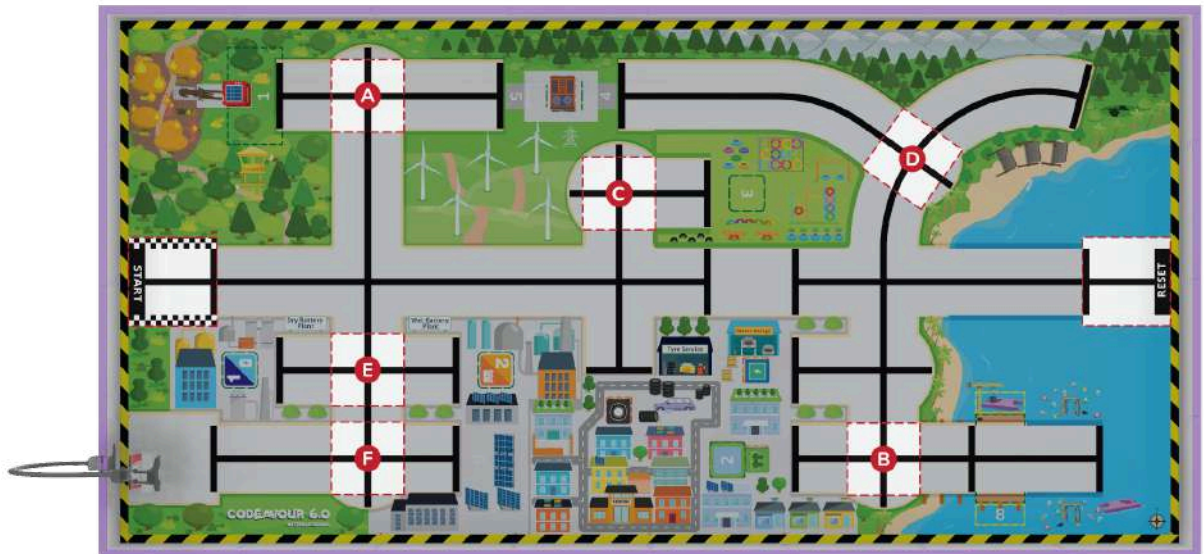

Robot Repositioning Points

Let's understand when to use which **Robot Repositioning Point** when you need to reposition your robot:

- i. For example, if your robot has attempted activity 1, your robot's repositioning point is 'A'.
- ii. If your robot has attempted activity number 2 or 8, your robot's repositioning point is 'B'.
- iii. If your robot has attempted activity 3, your robot's repositioning point is 'C'.
- iv. If your robot has attempted activity 4 or 7, your robot's repositioning point is 'D'.
- v. If your robot has attempted activity 5, your robot's repositioning point is 'E'.
- vi. If your robot has attempted activity 6, your robot's repositioning point is 'F'.
- vii. If your robot has just left the Start or Reset location, you must reposition it to the same location from which it departed.

- b. At any instance, if the team wants to touch the robot and/or the connected device (running PictoBlox):

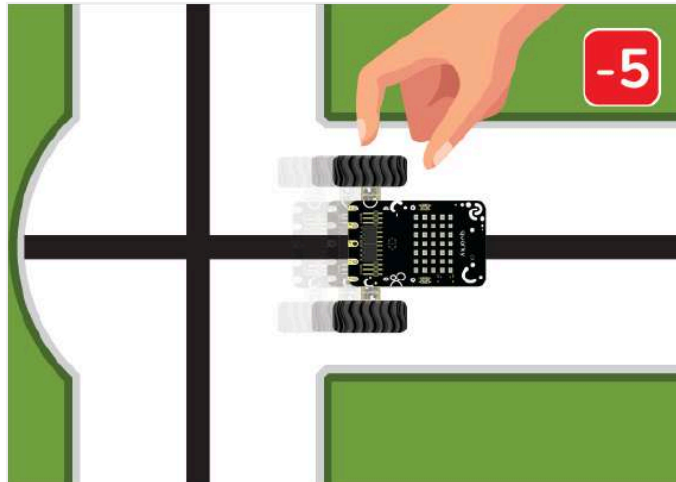

Touching the Robot

- i. The team must prompt the Judge for the same.
- ii. One foul will be called.
- iii. Team must:
 1. Move the robot by hand to the Robot Repositioning Point nearest to the Drop Point of the previously attempted challenge.

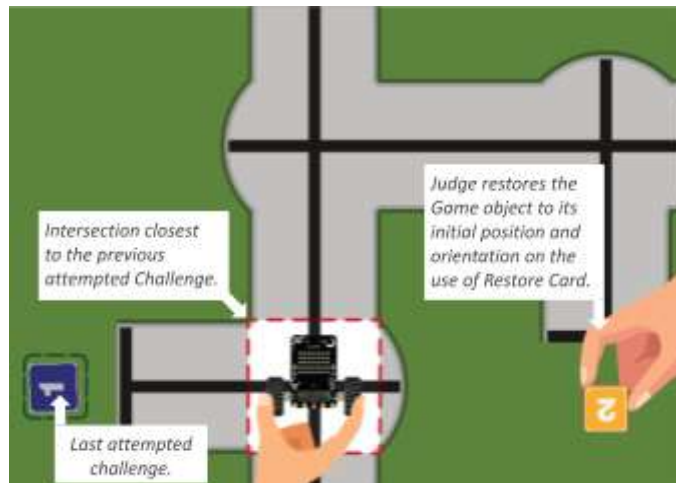

Repositioning Robot and Object

2. Execute the code to either reattempt this challenge or another one.
- iv. If the Quarky Cube/ Small Cube(s) of that challenge is/ are held by the robot:
 1. The cube(s) has to be given to the Judge/ Volunteer to be kept outside the arena.
 2. The Unique Mechanisms or Objects must not be touched by the team.

- 3. This attempt at the challenge will not be scored.
 - 4. The team can further exercise the **Restore Card** (if available) at any point of time to reattempt this challenge and the Judge/ Volunteer will restore the game object(s).
 - v. The timer won't be paused.
- c. If the robot leaves the track completely:

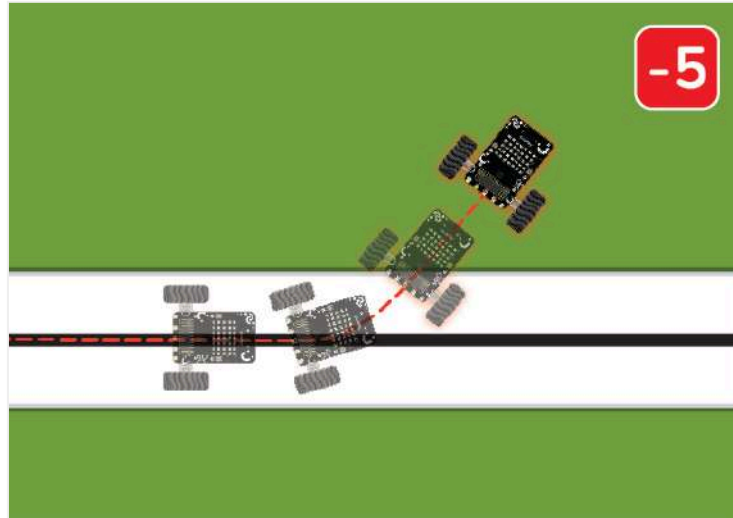

Path Deviation

- i. One foul will be called.
 - ii. Team must:
 - 1. Move the robot by hand to the Robot Repositioning Point nearest to the Drop Point of the previously attempted challenge.
 - 2. An Additional Foul will not be counted for hand touch.
 - 3. Execute the code to either reattempt this challenge or another one.
 - iii. If the robot has just started from the start or reset point and it has deviated before attempting any challenge:
 - 1. The robot needs to be repositioned at the respective point from which it had started.
 - 2. An additional Foul will not be counted for hand touch.
 - 3. Execute the code to either reattempt this challenge or another one.
 - iv. The timer won't be paused.
- d. If a team member touches the robot **without prompting the judge**:
- i. One foul will be called.
 - ii. The challenge will not be scored.
 - iii. The judge will end the round.

9. Evaluation and Scoring

- Teams should abide by the participation and submission guidelines; non-adherence to them will result in disqualification.
- The team must submit photos, videos, and detailed information about the robot on the Codeavour 6.0 submission portal.

During the competition (physical mode), the score will be given as per the following criteria:

- **Full Score:** You will get full points if the object is placed inside or positioned on the green line, i.e. the Drop point's placement area.

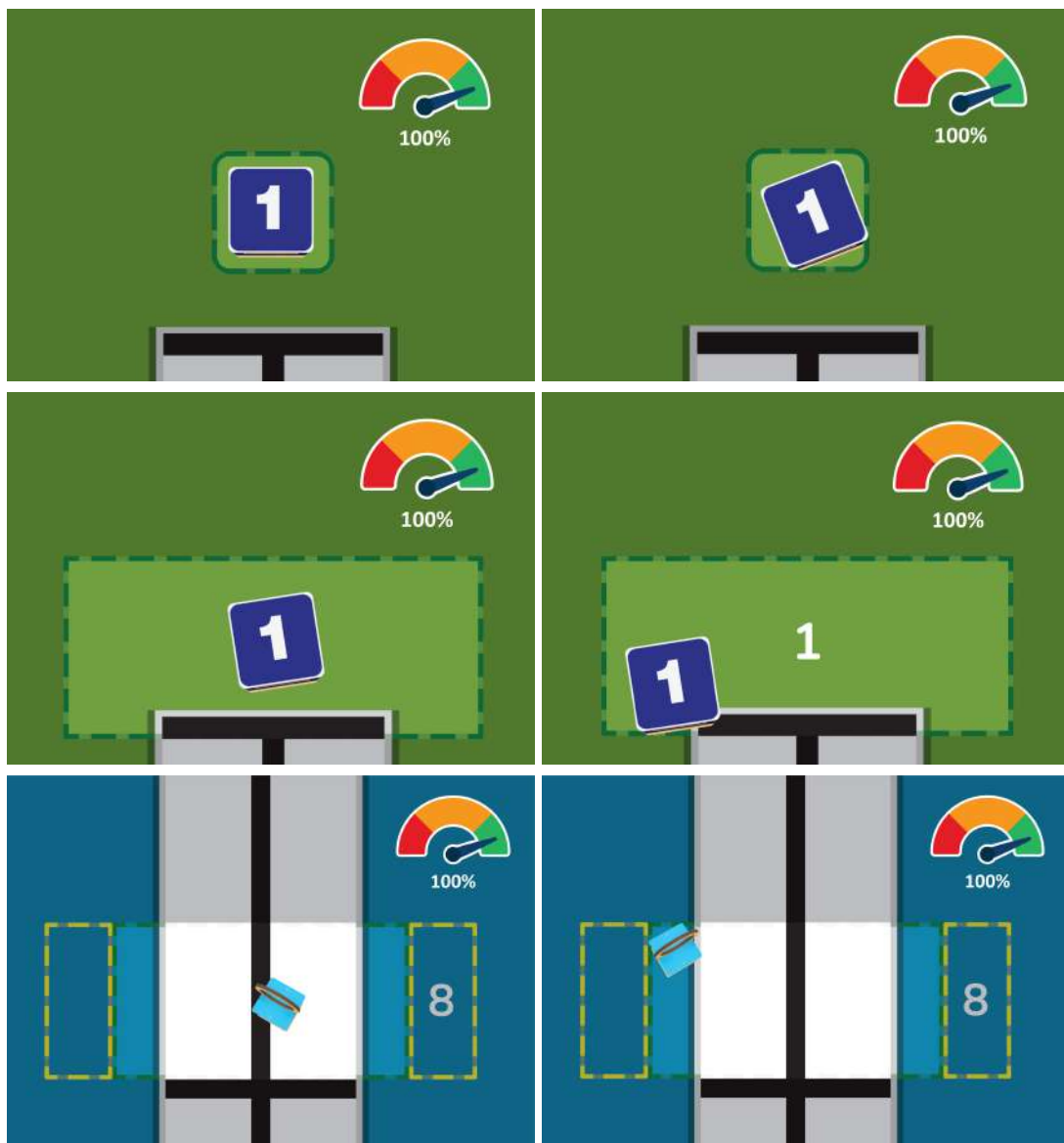

Full score at drop points

- **Half Score:** Objects that are partially outside the drop point (green box) or placed in the extended drop point (yellow box) will only score half.

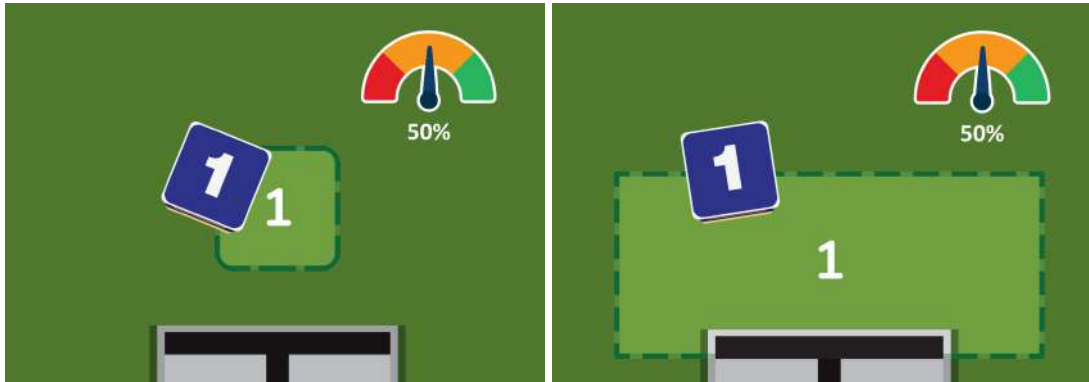

Half Score at drop points

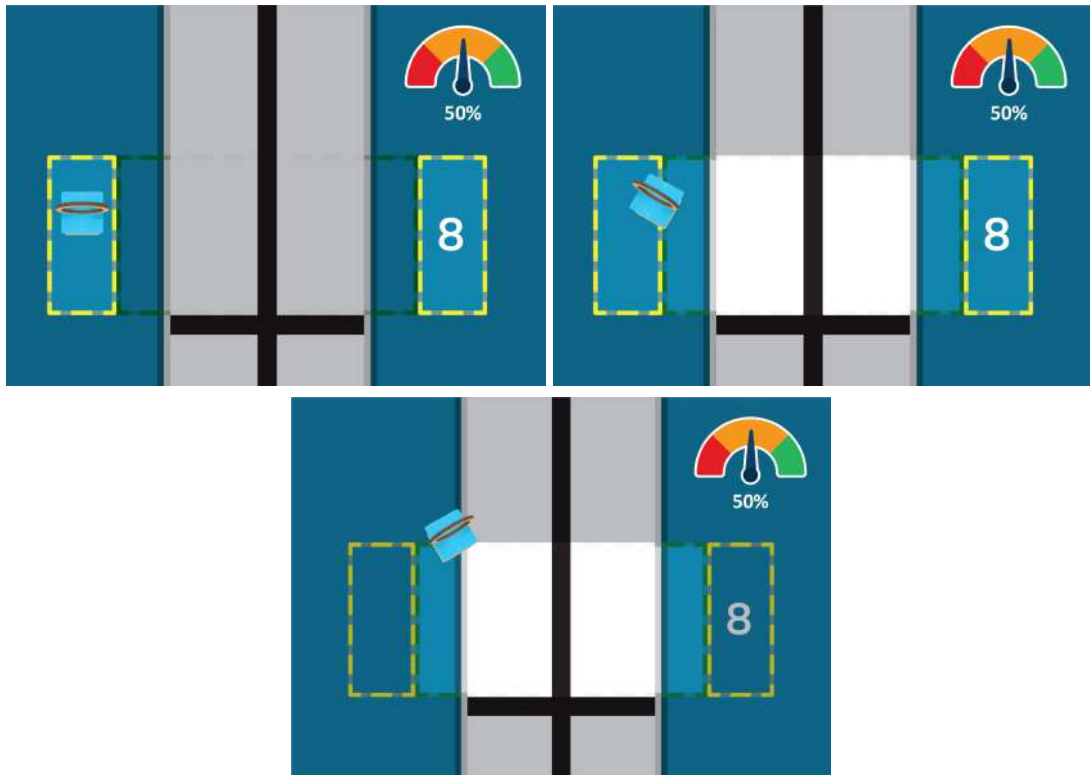

Half Score at extended drop points

Note: Extended drop points marked in yellow will score half the points compared to green drop points.

- **No Score:** A zero score will be considered if the object is placed entirely outside the designated area.

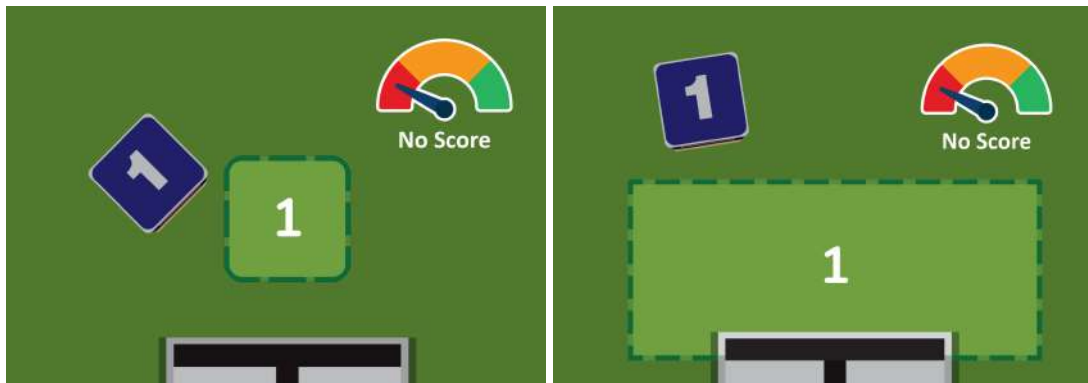

No score at drop points

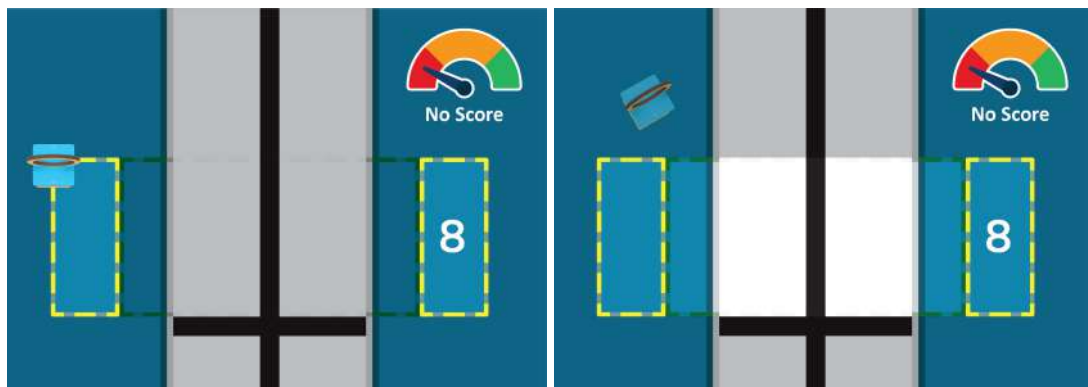

No score at drop points with an extension

- Participants are required to complete as many challenges as possible within the time limit. Unfinished tasks will not be awarded points once the time expires.
- Foul Shield Card(s) and Restore Card(s) that are returned unused at the end of the game will gain bonus points as per the scoring rubrics.
- The timer will not be paused once the game starts.

10. Change Notes

Kindly read the updated rules and sections listed below to stay informed about the latest modifications:

Version 1-2

Updates in Codeavour 6.0 Track 2 Rules and Regulation V2	
1.	6. Game Cards 6.1. Switch Card - Notes 6.1. Restore Card
2.	7. During the Competition Round 7.1. Do's 7.2. Don'ts
3.	8. Fouls

Version 2-3

Updates in Codeavour 6.0 Track 2 Rules and Regulation V2	
1.	1. Introduction 1.1.3. General Rules and Regulations 4. Climate Action Challenges 4.1.5 Challenge 5: Recycling Battery (using AI and ML)

11. Glossary

Glossary	
Game Field	The area within the competition arena where the robots perform the challenges and tasks.
Challenge	A specific task or problem that participants need to solve using their robots within a limited time frame.
Game Objects	Physical items are placed inside the arena that robots interact with during the challenges.
Pick and Place	A method of robot manipulation where the robot picks up an object from one location and places it in another.
Pick up Point	Area from where the Game Object is defined to be positioned before the respective challenge is attempted. This is marked with an orange outline.
Drop Point	Area where the robot is expected to move a Game Object as defined in the challenge. This is marked with a green outline.
Extended Drop Point	Area adjacent to the Drop Point where the robot can move a Game Object as defined in the challenge if it is unable to do so at the Drop Point itself. This is marked with a yellow outline.
Grab	A method of robot manipulation where the robot uses a gripping mechanism to hold and move objects.
Push Pull	A method of robot manipulation where the robot applies force to objects to push or pull them to desired locations.
Machine Learning Environment	The PictoBlox platform where machine learning models can be trained and exported further to Block or Python Coding Environments.
Robot Verification Team	The team checks that robots meet the specified requirements and guidelines before the competition.
Referee	An official is responsible for overseeing and judging the competition, ensuring fair play and adherence to the rules.
Table Number	A unique identifier is assigned to each competition table or area where teams perform their challenges.
Starting Point/Reset Point	Designated locations on the competition field from where the robots begin or can be reset during challenges.
Scoring Sheet	A record of each team's scores and performance during the competition.

Calibration	The process of adjusting and fine-tuning the robot's sensors and movements to ensure accuracy during challenges.
Foul Shield Card	A card that nullifies the negative scoring of a foul.
Teleport Card	A card allowing teams to move their robot instantly between predefined points on the field.
Switch Card	A card that allows teams to switch their robot from manual to autonomous mode or vice versa during the round.
Restore Card	A card that allows teams to request the Judge/volunteer to restore the position and orientation of a game object(s) of a challenge after a missed attempt.
Foul Exemptions	Instances where teams can avoid penalties by redeeming Foul Shield Cards strategically.
Quarky Expansion Board	An additional board can be attached to the Quarky microcontroller to extend its capabilities.
Practice Arena	An allocated space where teams can test and set up their robots before the competition round.
AI (Artificial Intelligence)	The simulation of human intelligence processes machines, especially computer systems, to perform tasks that typically require human intelligence, such as visual perception, speech recognition, decision-making, and language translation.
Autonomous Robot	A robot which can operate without human intervention, following a predetermined set of instructions or responding to its environment using sensors and algorithms.
Manual Robot	A robot that is controlled in real-time by a human using input interfaces.
Codeavour	The name of the international robotics competition is mentioned in the rule book.
DIY (Do-It-Yourself)	The practice of building, modifying, or repairing something without the direct aid of experts or professionals.
FHD (Full High Definition)	A display resolution of 1920 x 1080 pixels, providing high-quality visual content.
FOV (Field of View)	A camera or other optical device can see the extent of the observable world at any given moment.
Game Arena	The designated competition area where robots perform tasks and challenges.
Machine Learning	The ability to automatically learn and improve from experience without being explicitly programmed, often used in pattern recognition and

	decision-making.
PictoBlox	The specified programming software used for programming the robots in the competition.
Quarky	The specified hardware/microcontroller used for building robots in the competition.
Robotics	The interdisciplinary field integrates mechanical engineering, electronics, computer science, and artificial intelligence to design, build, and operate robots.
Sensors	Devices that detect and respond to inputs from the physical environment, such as light, heat, motion, or pressure.
Teleportation Strategy	A strategic move where the robot is instantly moved between predefined starting or reset points on the competition field.
Track	The specific category or type of competition within the overall robotics event (e.g. Track-2: Climate Action Challenge).
Wired Connection	A physical connection using wires or cables to transfer data or power between devices.
Wireless Connection	A connection that allows data or power transfer between devices without the need for physical wires or cables.

Important: Please note that minor updates to this competition's rules and guidelines may be made before/during the competition to ensure accuracy and fairness. Before the competition, you will receive your time slot and table number.